

Staff – View and Print Class Rosters

Viewing and Printing Single Class Roster by Class Number 1
 Viewing and Printing Multiple Class Roster 4

Viewing and Printing Single Class Roster by Class Number

Home > Campus Community > USM Campus Community > Reporting > USM Class Roster

FIRST TIME ONLY:

1. The first time you print a class roster you will want to add a new value. Click on the **Add a New Value** tab.
2. Run Control ID: Enter a “title” for this process.

3. Click on the **Add** button

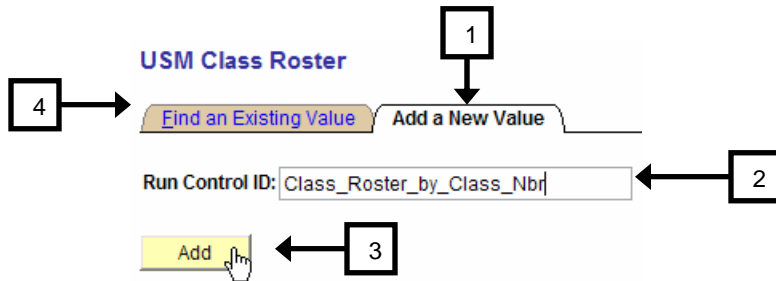

4. On returning here, you can use the **Find an Existing Value** tab and enter the process title you entered.

EVERY TIME:

1. Academic Institution: Enter USM01 or use search.
2. Term: Enter appropriate term code or use search.
3. Campus: Enter campus code or use search.
4. Academic Career: Enter career code or use search.
5. Specific Class: Check to activate.
6. Class Nbr: Enter the class registration number.
7. Click on the button to add another class.

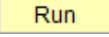
8. Click on the  button.
9. Click on the  button.

Usm Rc Strc044

Run Control ID: Class_Roster_by_Class_Nbr [Report Manager](#) [Process Monitor](#)  ← **9**

*Academic Institution:  ← **1** Univ of Southern Mississippi

*Term:  ← **2** Summer 2006-2007

Scroll Area Find | View All First 1 of 1 Last

Sequence Number: Session:

*Campus:  ← **3** Hurg

*Academic Career:  ← **4**

Subject Area:

Specific Class: ← **5**

Class Nbr:  ← **6**

Include:



Enrolled:

Waiting:

Drop:

Permissions:

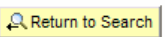
7 ↑

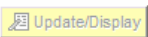
8 →     

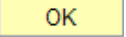
10. Server Name: Choose "PSUNX".
11. Type: Choose "Web".
12. Format: Choose "PDF".
13. Click on the  button.

Process Scheduler Request

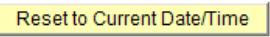

User ID: W301906 **10** Run Control ID: Class_Roster_by_Class_Nbr

Server Name: Run Date: 

Recurrence: Run Time: 

Time Zone:

Select	Description	Process Name	Process Type	*Type	*Format	Distribution
<input checked="" type="checkbox"/>	USM Class Roster	STRC044	SQR Report	<input type="text" value="Web"/>	<input type="text" value="PDF"/>	Distribution

13 ↓  

11 ↑ **12** ↑

14. Click on the [Report Manager](#) link.

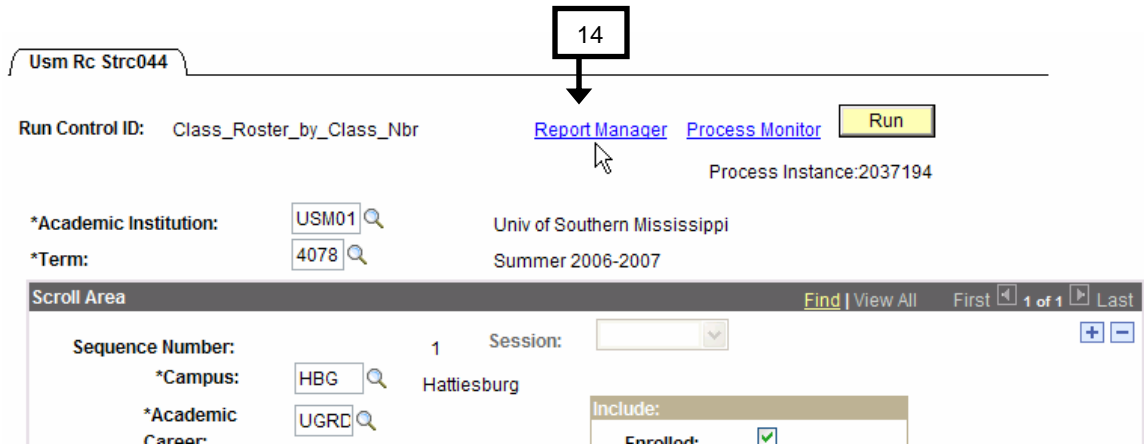

15. Click on the **Refresh** button until you see “Posted” in the Status column.

16. Under the “Description” column, click on the [USM Class Roster](#) link associated with your report once status is “Posted.”

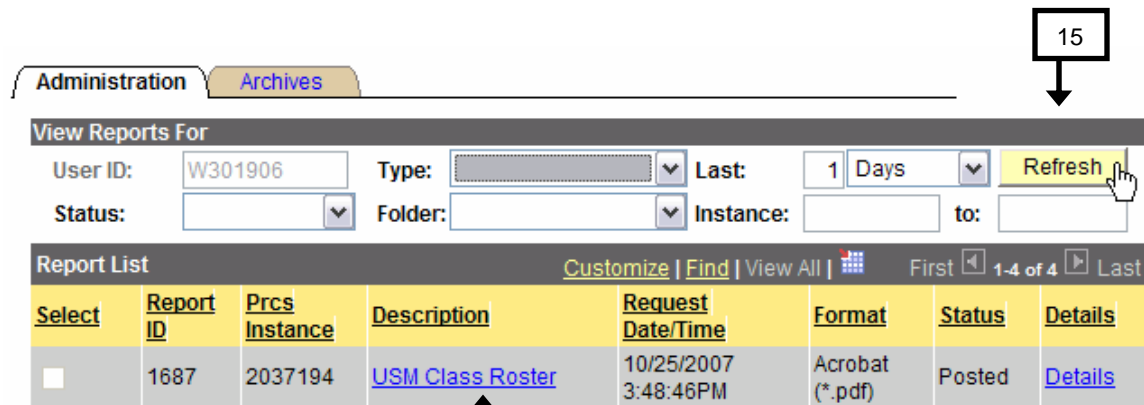

17. A new window will appear.

NOTE: Turn off all pop-up blockers!!!!

18. Use the “zoom” feature to enlarge the view.

19. Use the  button to print.

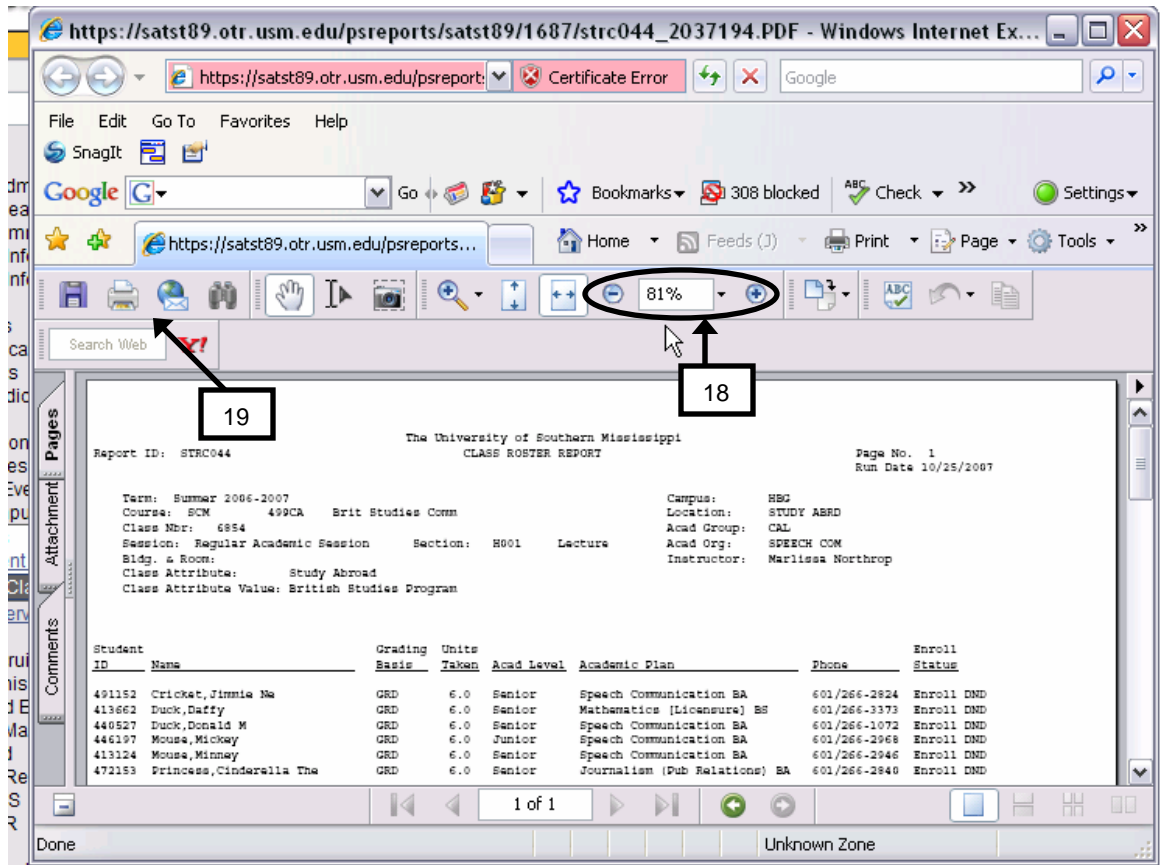

Viewing and Printing Multiple Class Roster

Home > Campus Community > USM Campus Community > Reporting > USM Class Roster





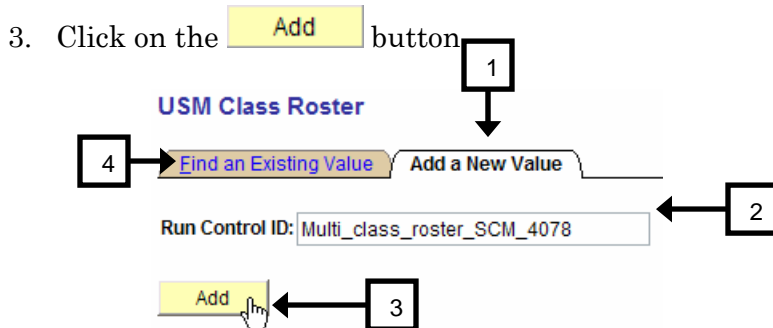

FIRST TIME ONLY:

1. The first time you print a class roster you will want to add a new value. Click on the **Add a New Value** tab.
2. Run Control ID: Enter a "title" for this process.



4. On returning here, you can use the **Find an Existing Value** tab and enter the process title you entered.
5. It will display in the Search Results area. Simply, click on it and continue the process.

EVERY TIME:

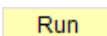
1. Academic Institution: Enter USM01 or use  search.
2. Term: Enter appropriate term code or use  search.
3. Campus: Enter campus code or use  search.
4. Academic Career: Enter career code or use  search.
5. Subject Area: Enter subject area of interest.
6. Click on the  button to add another subject area.
7. Click on the  button.
8. Click on the  button.

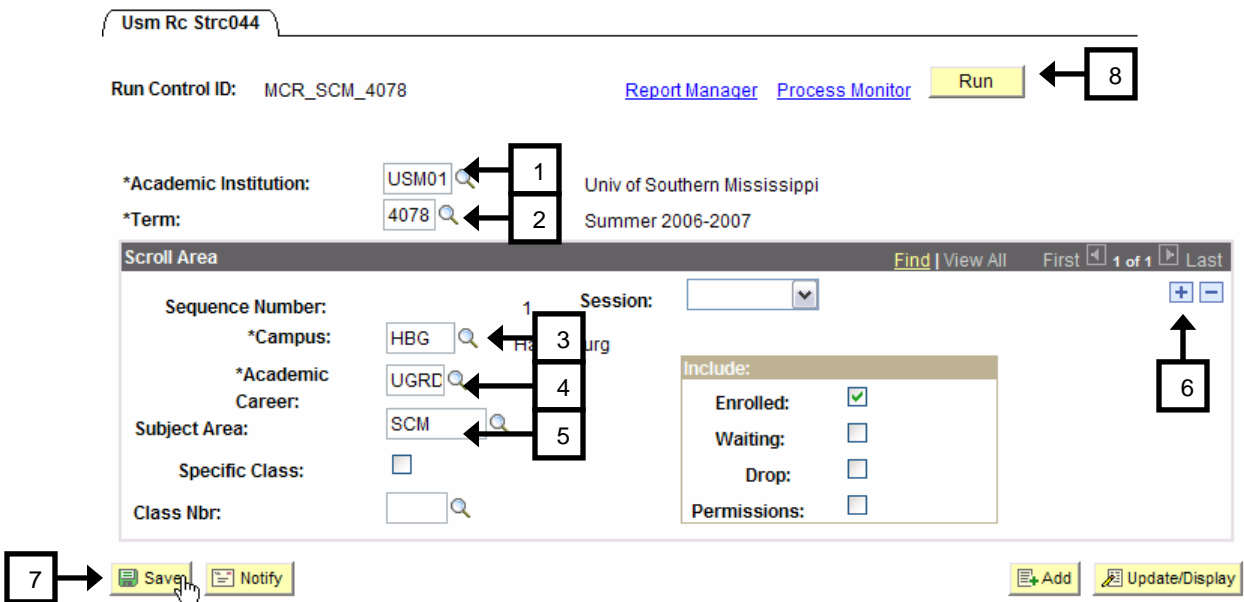

9. Server Name: Choose "PSUNX".
10. Type: Choose "Web".

11. Format: Choose "PDF".

12. Click on the **OK** button.

Process Scheduler Request

User ID: W301906 9 Run Control ID: MCR_SCM_4078

Server Name: PSUNX Run Date: 10/25/2007
 Recurrence: Run Time: 4:07:03PM **Reset to Current Date/Time**

Time Zone:

Select	Description	Process Name	Process Type	*Type	*Format	Distribution
<input checked="" type="checkbox"/>	USM Class Roster	STRC044	SQR Report	Web	PDF	Distribution

12 → **OK** **Cancel**
↑ 10
↑ 11

13. Click on the [Report Manager](#) link.

Usm Rc Strc044 13

Run Control ID: MCR_SCM_4078 [Report Manager](#) [Process Monitor](#) **Run**

Process Instance:2037197

*Academic Institution: USM01 Univ of Southern Mississippi
 *Term: 4078 Summer 2006-2007

Scroll Area Find | View All First 1 of 1 Last

Sequence Number: 1 Session:
 *Campus: HBG Hattiesburg
 *Academic Career: UGRD
 Include:
 Enroll:

14. Click on the **Refresh** button until you see "Posted" in the Status column.

NOTE: This may take several clicks.

15. Under the "Description" column, click on the [USM Class Roster](#) link associated with your report once status is "Posted."

14

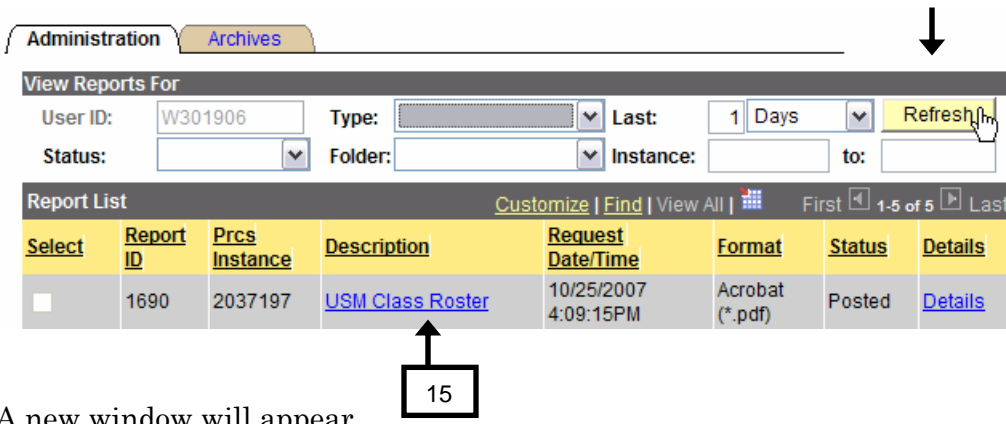

16. A new window will appear.

NOTE: Turn off all pop-up blockers!!!!

17. Use the “zoom” feature to enlarge the view.

18. Use the  button to print.

