

Student Worksheet

Charles' Law

Name _____

Date _____

Introduction

In this experiment we shall place a drop of water into the stem of an empty Beral pipet. The drop will cling to the sides of the pipet stem. This results in the air in the bulb being “trapped” by the drop of water. You will be measuring the distance this drop moves when the pipet is heated.

Materials (for each pair of students)

- a Beral pipet with attached transparent plastic metric ruler
- a thin stem Beral pipet
- Containers of cold and hot water (about 55°C)
- Small amount of colored water
- Thermometer (-10 to 110°C)
- Graph paper
- Stirring rod
- Tissue or paper towels
- Magnifying glass
- bath container

Procedure

1. Immerse the bulb and 3/4 of the stem of the pipet with the ruler attached in a container of cold water (10° to 15°C) for three to five minutes.
2. **Without removing the bulb from the cold water,** use the extended stem pipet to insert a small drop of colored water into the stem of the first pipet as near the bulb as possible without getting liquid in the bulb. This drop seals off the air in the pipet bulb.
3. **Without removing the pipet from the water,** use the ruler to read the distance from the edge of the bulb to the back edge of the water drop (the distance from A to B in Figure 1). Read the value in millimeters to two decimal places [e.g. 0.xx mm.].

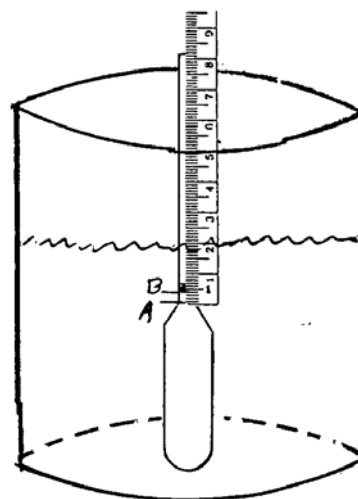

Figure 1

Record this distance as well as the temperature of the water bath on the Data Sheet.

4. Add a small amount of hot water to the cold water in the container to raise the temperature by 6-8 degrees. (If you add too much hot water, use small amounts of cold water to bring the temperature back down to within the 6-8 degree range.) Be sure to stir the water.

5. Allow two to three minutes for the temperature to stabilize.
6. Record on the data sheet:
 - (a) the new temperature of the water
 - (b) the new increased distance from the edge of the bulb to the back edge of the water drop (caused by the expansion of the trapped air due to the increase in temperature).
7. Repeat Steps 4-6 as many times as possible until it is clear that additional heat would cause the water drop to leave the pipet stem. (The temperature will be between 40 and 55°C.) Keep in mind that, as the drop of liquid moves up the stem, the portion of the pipet below the drop must be immersed in the water bath.
8. Convert the temperature readings recorded in degrees Centigrade on the data sheet to absolute temperature (in Kelvin).
9. The pipet bulb has a volume of approximately 3.85 mL. Each mm of the pipet stem is proportional to approximately 0.01 mL. Use this information to convert the measured distances recorded on the data sheet to volume readings.
10. Plot the volume (y axis) versus the absolute temperature (x axis) on a piece of graph paper.

DATA SHEET

<u>Temp °C</u>		<u>Temp K</u>	<u>Stem Distance in mm</u>	<u>V (mL)</u>
1. ____	+ 273 =	____	____ mm x 0.01 mL/mm + 3.85 mL =	_____
2. ____	+ 273 =	____	____ mm x 0.01 mL/mm + 3.85 mL =	_____
3. ____	+ 273 =	____	____ mm x 0.01 mL/mm + 3.85 mL =	_____
4. ____	+ 273 =	____	____ mm x 0.01 mL/mm + 3.85 mL =	_____
5. ____	+ 273 =	____	____ mm x 0.01 mL/mm + 3.85 mL =	_____
6. ____	+ 273 =	____	____ mm x 0.01 mL/mm + 3.85 mL =	_____
7. ____	+ 273 =	____	____ mm x 0.01 mL/mm + 3.85 mL =	_____
8. ____	+ 273 =	____	____ mm x 0.01 mL/mm + 3.85 mL =	_____

Plot your results on a piece of graph paper.

Questions

1. Does increase in temperature increase or decrease the volume of a gas? Explain your answer.
2. Why is 273 added to the temperature in °C?
3. Why is the stem distance multiplied by 0.01?
4. Where does the 3.85 come from?
5. If all of the air trapped beneath the drop of colored water is not immersed in the bath, will it affect the reading which you take? Explain your answer.
6. How can you verify whether your response to question 4 is correct?
7. What would you expect to happen if the drop of colored water is added before chilling the bulb?
8. How can you verify whether your response to question 7 is correct?